

#### ATENÇÃO

1. Ler antes de iniciar a montagem
2. A montagem do produto deverá ser feita em uma superfície limpa e plana. Aconselhamos utilizar a embalagem para forrar o chão a fim de não danificar o produto.
3. Os parafusos devem ser apertados periodicamente.
4. Evitar batidas e contatos com objetos cortantes.

#### LIMPEZA

1. Pano levemente umedecido com água, seguido de pano seco.
2. Não utilizar produtos químicos abrasivos.

#### IMPORTANTE

UTILIZAR AS FERRAMENTAS CORRETAMENTE  
EVITANDO O USO DE MATERIAIS QUE POSSAM  
CAUSAR DANOS AO PRODUTO.

A MONTAGEM DO PRODUTO DEVERÁ SER  
FEITA EM SUPERFÍCIE LIMPA E PLANA.



REF:	DESCRIÇÃO	MATERIAL	QUANT.	Comprimento	Largura
01	LATERAL DIREITA	AGLOM 15 MM	1	1,100	0,425
02	LATERAL ESQUERDA	AGLOM 15 MM	1	1,100	0,425
03	DIVISÓRIA CENTRAL	AGLOM 15 MM	1	1,100	0,425
04	PRATELEIRA	AGLOM 15 MM	3	0,645	0,425
05	PORTA	AGLOM 15 MM	2	0,945	0,327
06	BASE	AGLOM 15 MM	1	1,345	0,445
07	FRENTE GAVETA	AGLOM 15 MM	3	0,657	0,215
08	FRENTE GAVETÃO	AGLOM 15 MM	1	0,657	0,435
09	LATERAL GAVETA	AGLOM 15 MM	6	0,400	0,128
10	LATERAL GAVETÃO	AGLOM 15 MM	2	0,400	0,300
11	CONTRA FUNDO GAVETA	AGLOM 15 MM	3	0,622	0,128
12	CONTRA FUNDO GAVETÃO	AGLOM 15 MM	1	0,622	0,275
13	TRAVA GAVETA	AGLOM 15 MM	5	0,400	0,060
14	TAMPO SUPERIOR	MDF 20 MM	1	1,365	0,465
15	FUNDO TRASEIRO	MDF 2,5 MM	4	1,125	0,328
16	FUNDO GAVETA	MDF 2,5 MM	4	0,605	0,410
17	TRAVA	AGLOM 15 MM	1	0,645	0,060

### LEGENDA - RELAÇÃO DE ACESSÓRIOS

Nº	DESCRIÇÃO	QUANT.	ILUSTRAÇÃO
A	<b>CAVILHA 8X30</b>	<b>66</b>	
B	<b>PARAFUSO 4,5X50 CHATO</b>	<b>20</b>	
C	<b>PARAFUSO 3,5X14 CHATO</b>	<b>64</b>	
D	<b>PARAFUSO 4X40 CHATO</b>	<b>6</b>	
E	<b>PARAFUSO 3,5X30 FLANG</b>	<b>12</b>	
F	<b>PINO MINIFIX</b>	<b>26</b>	
G	<b>TAMBOR MINIFIX</b>	<b>26</b>	
H	<b>PREGO 10X10</b>	<b>80</b>	
I	<b>GARRA PARA FUDO</b>	<b>12</b>	
J	<b>DOBRADIÇA 26 MM</b>	<b>4</b>	
L	<b>TRILHO TELESCOPICO 32X350</b>	<b>4</b>	
M	<b>PERFIL H 1095</b>	<b>2</b>	
N	<b>PÉS DE MADEIRA</b>	<b>6</b>	
O	<b>PUXADOR DE MADEIRA 300</b>	<b>6</b>	

# PREPARAÇÃO DAS PEÇAS

QTD. DE ACESS. 

A	12
---	----

  
NESTE PASSO

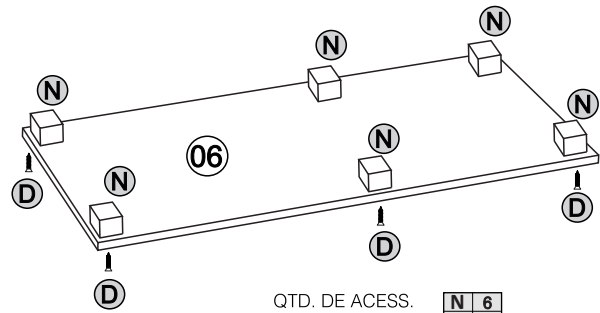
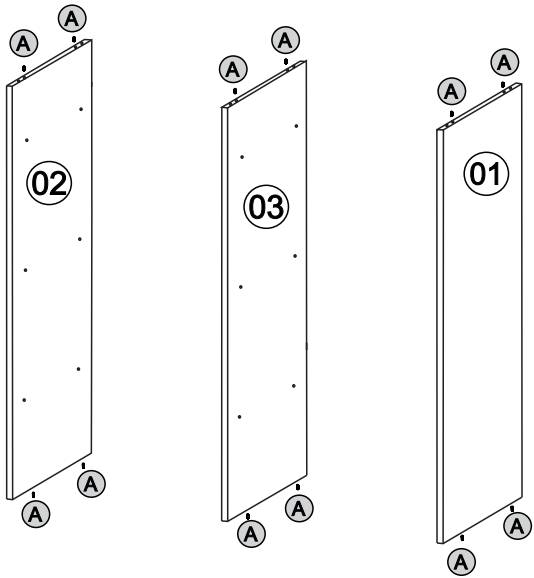

QTD. DE ACESS. 

N	6
D	6

  
NESTE PASSO

QTD. DE ACESS. 

F	6
---	---

  
NESTE PASSO

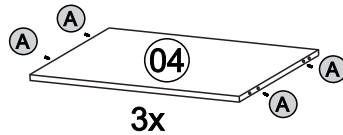
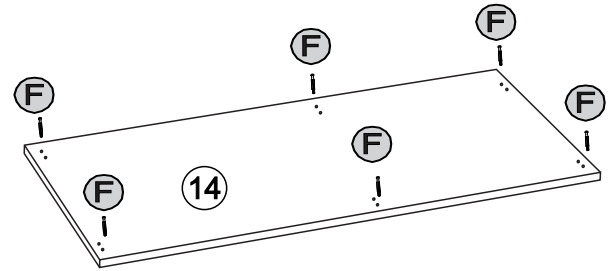

3x  
QTD. DE ACESS. 

A	12
---	----

  
NESTE PASSO

## 1º PASSO

QTD. DE ACESS. 

B	20
---	----

  
NESTE PASSO

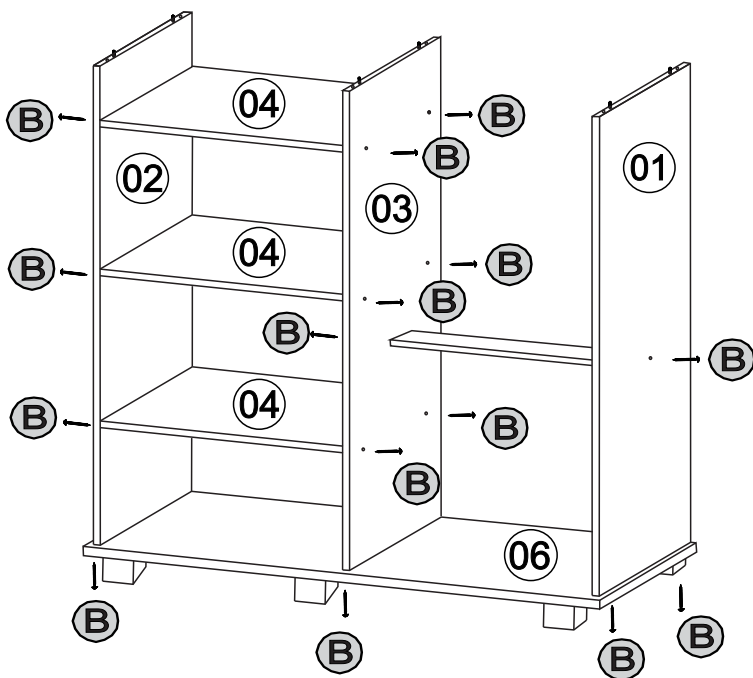

## 2º PASSO

QTD. DE ACESS. 

G	6
L	4
C	24

  
NESTE PASSO

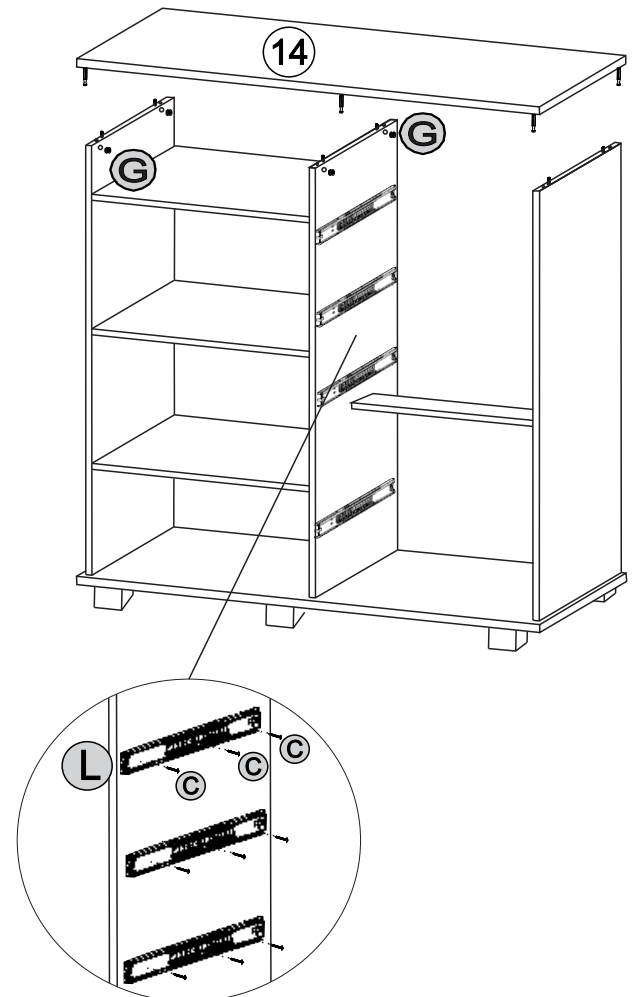

### 3º PASSO

QTD. DE ACESS.  
NESTE PASSO

H	80
I	12
M	2

### 4º PASSO

ACESSÓRIOS UTILZADOS NESTE PASSO:  
NÚMERO DE ACESSÓRIOS  
POR GAVETA:

A	10
F	4
G	4
O	1
L	2
C	6

PREGUE OS FUNDOS

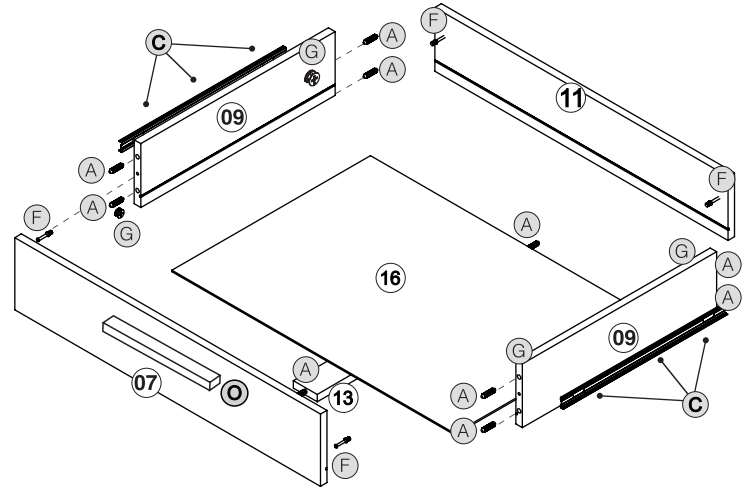
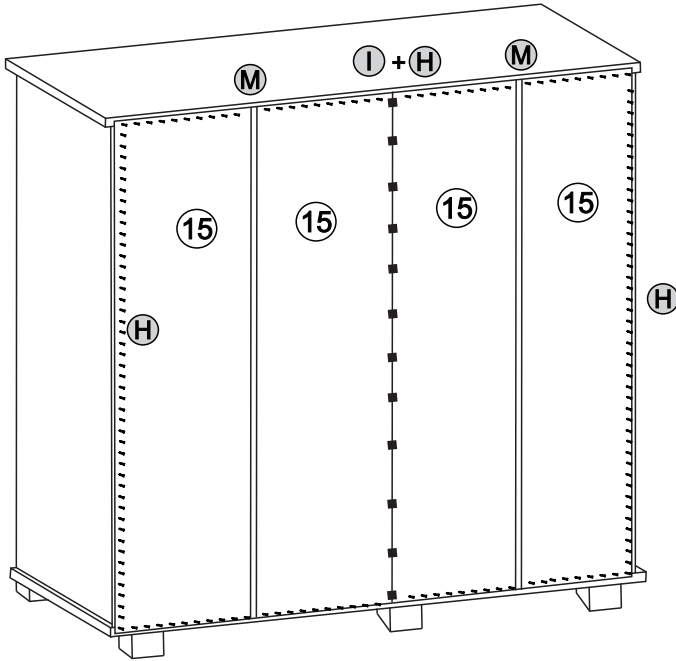

O GAVETÃO DEVE SER MONTADO DE IGUAL MODO UTILIZANDO AS PEÇAS (8, 10, 12, 16 E DUAS PEÇAS 13)

### 5º PASSO

QTD. DE ACESS.  
NESTE PASSO

J	4
C	16
E	4
O	2

